

THIELENHAUS

+ SUPERFINISH INNOVATION

modular • flexible • economical • universal

Bandfinisher SL100



Technology-benefits

The optimized surface produces less friction and therefore improves the wearing, the durability, the noise development and the energy expenditure.

This kind of surfaceimprovement is simple – compared to other principles – process-safe and economical.

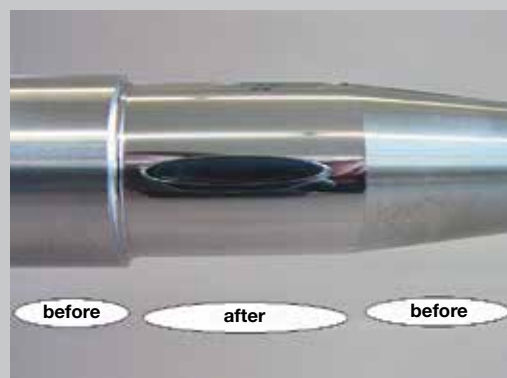

SBM control box manual
for manual finishing of individual parts and small series



SBA control box automatic
for time-regulated cut-in-finishing of individual parts and small series

Bandfinisher SL100 – Technical datas

Oscillation rate:	300 – 1400 double-strokes/min.
Oscillation path:	+/- 2 mm (bis max. +/- 3 mm)
Automated tape feed:	0 – 150 mm/min.
Pressing-on move:	30 mm
Pressing-on force:	max. 700 N
Pressing-on roll width:	100 mm (150 mm)
Pressing-on roll hardness:	Standard 65 ShA; optional: 35, 50, 90 ShA
Control voltage:	24 VDC
Weight:	38 kg

Adaptors

Electric:	230 V / 50 Hz
Pneumatic:	1 x 6 bar



Options

Control cabinet: Operation and regulation on device

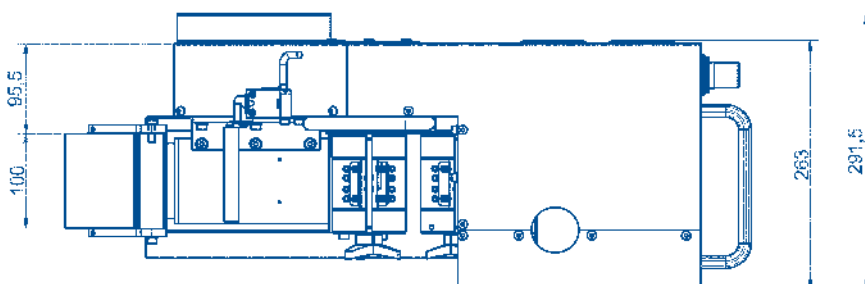
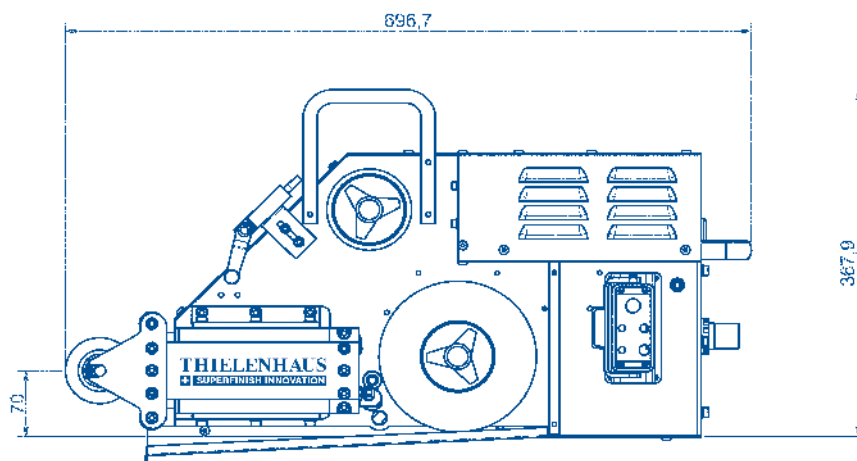
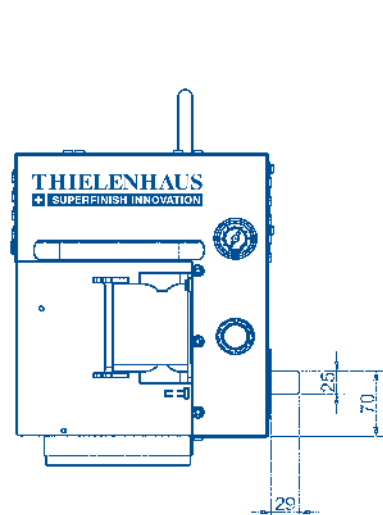

SUPERFINISH – a company of Thielenhaus Technologies

UK & Ireland Agent

**MASTER
ABRASIVES**

Phone: 01327 703813

Email: sales@master-abrasives.co.uk

www.master-abrasives.co.uk



Thielenhaus
Superfinish Innovation AG
St. Gallerstr. 52 CH-9548 Matzingen
Phone: +41 (0)52 376 26 20
info@superfinish.ch
www.superfinish.ch