

# THIELENHAUS

**+ SUPERFINISH INNOVATION**

modular • flexible • economical • universal

## Bandfinisher SL50

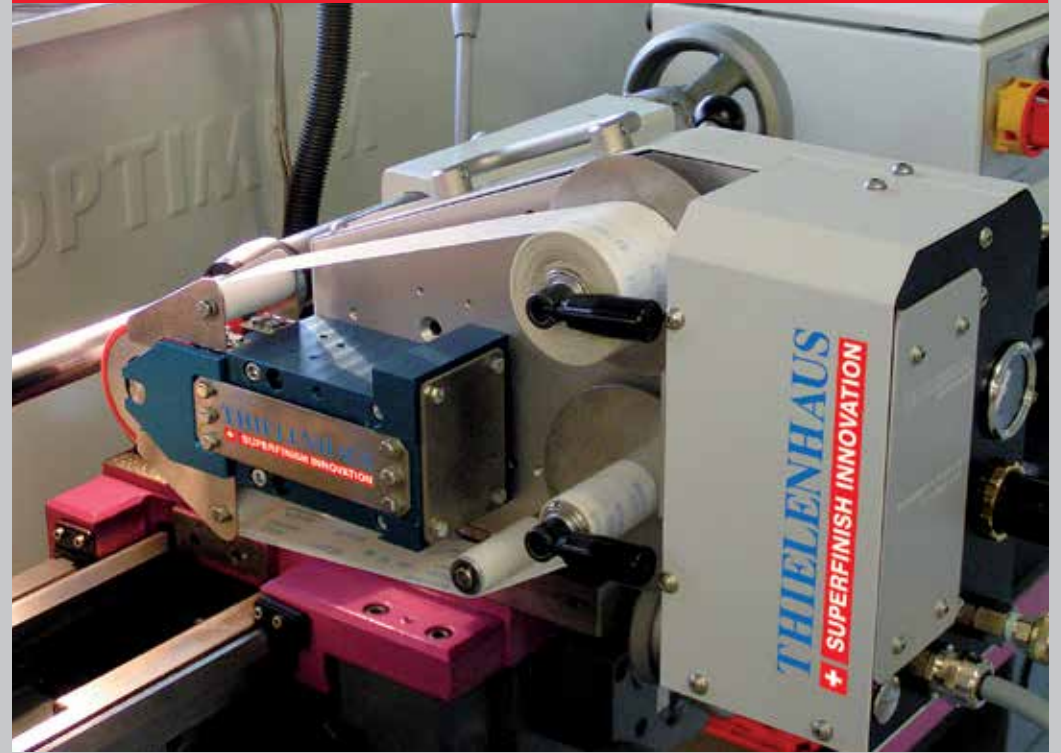

### Technology-benefits

The optimized surface produces less friction and therefore improves the wearing, the durability, the noise development and the energy expenditure.

This kind of surfaceimprovement is simple – compared to other principles – process-safe and economical.

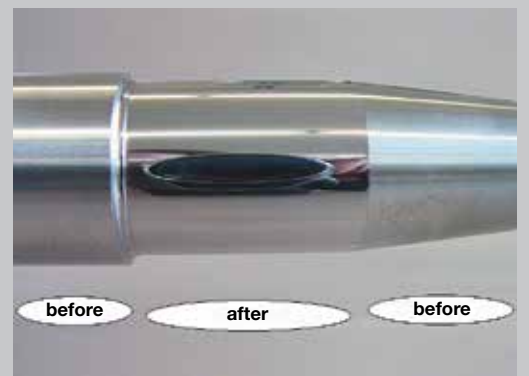

**SBM control box manual**  
for manual finishing of individual parts and small series



**SBA control box automatic**  
for time-regulated cut-in-finishing of individual parts and small series

### Bandfinisher SL50 – Technical datas

Oscillation rate:	300 – 1400 double-strokes/min.
Oscillation path:	Standard +/- 1 mm optional: +/- 0,5; +/- 1,5; +/- 2 mm
Automated tape feed:	10 – 100 mm/min.
Pressing-on move:	Standard 30 mm; optional : 40 mm
Pressing-on force:	50 – 300 N (1 – 6 bar)
Pressing-on roll width:	max. 50 mm
Pressing-on roll hardness:	Standard 65 ShA; optional: 35, 50, 90 ShA
Control voltage:	24 VDC
Weight:	13 kg

### Adaptors

Electric:	100 – 260 VAC, 50/60 Hz, 6 A (L, N, PE)
Pneumatic:	1 x 6 bar



### Options

- Machine device for direct assembly with sensors
- One-sided arranged pressing roll
- Special pressing-on roll

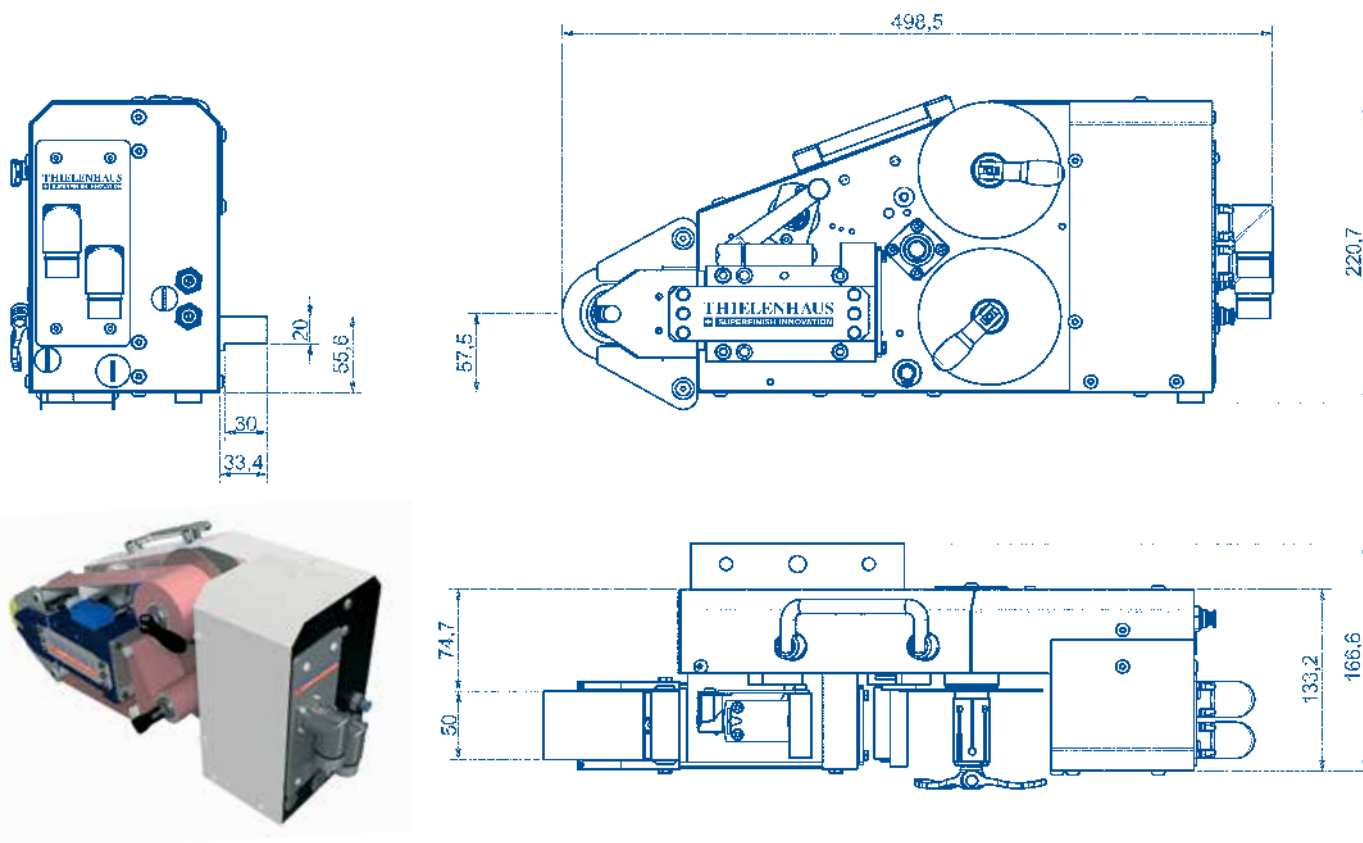

**SUPERFINISH – a company of Thielenhaus Technologies**

**UK & Ireland Agent**

**MASTER  
ABRASIVES**

Phone: 01327 703813

Email: sales@master-abrasives.co.uk

www.master-abrasives.co.uk



Thielenhaus  
Superfinish Innovation AG  
St. Gallerstr. 52 CH-9548 Matzingen  
Phone: +41 (0)52 376 26 20  
info@superfinish.ch  
www.superfinish.ch